

1011t tweeter

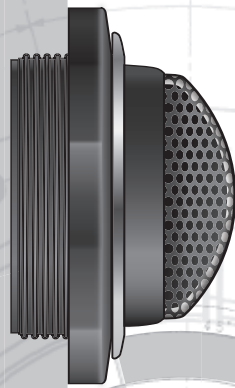

Infinity®

instructions

reference series

## INSTALLATION WARNINGS AND TIPS

**THANK YOU** for purchasing Infinity's Reference Series tweeter. We've organized this manual to make your installation as simple and trouble-free as possible. Please read it thoroughly before proceeding.

Remember to keep your sales receipt with this manual in a safe place so both are available for future reference.

### ABOUT THESE INSTRUCTIONS

Installation of automotive stereo components can require extensive experience with a variety of mechanical and electrical procedures.

Although these instructions explain how to install Reference 1011t tweeters in a general sense, they do not show the exact installation methods for your particular vehicle. If you feel you do not have the experience, do not attempt the installation yourself; instead, ask your authorized Infinity car audio dealer about professional installation options.

### LOUD MUSIC AND HEARING

Playing loud music in an automobile can permanently damage your hearing, as well as hinder your ability to hear traffic. The maximum volume levels achievable with Infinity speakers, combined with high power amplification, may exceed safe levels for extended listening. We recommend using low volume levels when driving. Infinity accepts no liability for hearing loss, bodily injury, or property damage as a result of use or misuse of this product.

### ABOUT THE CROSSOVER

Passive crossover design involves precise circuit design and component selection. Moreover, a well-designed crossover circuit provides an intended electrical response, when combined with the electrical properties of the speaker, to provide a particular acoustic response. Each enclosed crossover has been optimized to provide a flat response when used with a Reference 1011t tweeter.

**Do not use another brand or type of passive crossover, or connect more than one tweeter to a crossover. Doing so may damage the tweeter.**

### INSTALLATION TIPS

- Always wear protective eyewear when using any tools.
- Turn off all audio components and other electrical devices before you start. Disconnect the negative (-) lead from your vehicle's battery.
- Keep speakers in their package until final installation. When moving a speaker, always rest it with the cone or dome facing up. Never use force to install any speaker.
- Check clearances on both sides of a planned mounting surface before drilling any holes or installing any screws. Remember that the screws can extend behind the surface.
- At the installation sites, locate and make a note of all fuel lines, hydraulic brake lines, vacuum lines and electrical wiring. Use extreme caution when cutting or drilling in and around these areas.
- Before drilling or cutting holes, use a utility knife to remove unwanted fabric or vinyl to keep material from snagging in a drill bit or saw.
- For door installations, check the clearance with the windows throughout the range of the window's travel, and verify that a mounted speaker will not interfere with the window crank or power-window mechanism.
- If mounting speakers elsewhere, check for clearance around rear-deck torsion bars, glove box or other structural elements.
- Do not mount speakers where they will get wet.

## SPEAKER PLACEMENT

### ABOUT PLACEMENT

Figures 1 and 2 show possible speaker placements with Figure 1 being more desirable. We recommend using the kick panel for mounting to obtain the best staging and imaging in most vehicles.

**Figure 1.** Mounting the woofer and tweeter in the kick panel.

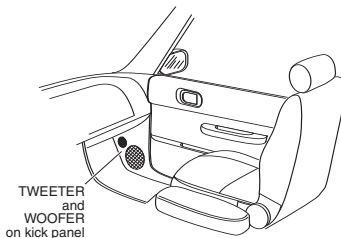

**Figure 2.** Mounting the woofer in the door and the tweeter in the kick panel.

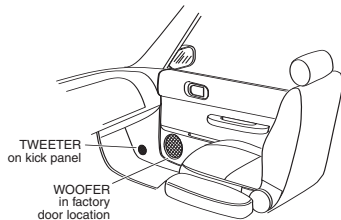

## TWEETER INSTALLATION

### SURFACE-MOUNT

**Figure 3.** Surface-mounting the tweeter and connecting the crossover.

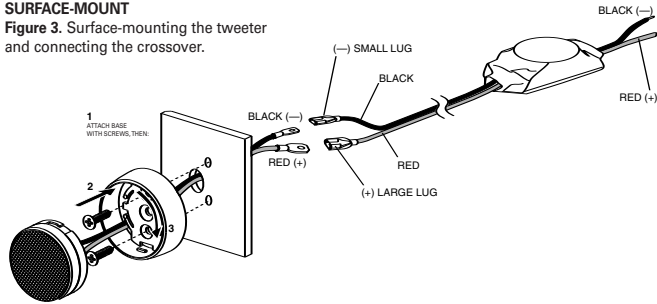

### FLUSH-MOUNT

**Figure 4.** Mounting the tweeter using the I-Mount™ (patent no. 5,859,917) flush-mounting kit. Also see Figure 5.

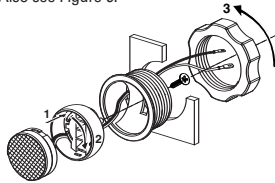

### TWEETER ANGLE

**Figure 5.** Aiming the tweeter at a desired listening position.

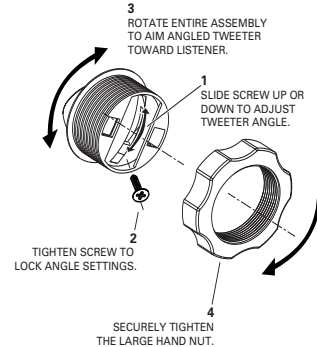

**Figures 6A through 6D.** The Starfish™ tweeter mount is intended to be used when the tweeter will be installed behind a factory grille (e.g., replacing the factory tweeter behind a door panel). The Starfish will allow you to mount the component tweeter directly to the panel itself or to the area behind the panel. The six mounting tabs can be removed easily to create a number of custom configurations.

*Note: Check screw clearance before installing. Use glue if clearance is an issue.*

*Note: Not all possible mounting configurations are shown.*

**Figure 6A.** Behind grille panel.

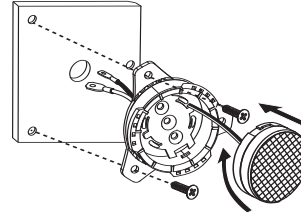

**Figure 6B.** Mounted to surface behind grille panel.

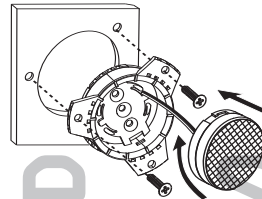

**Figure 6C.** Mounted to grille panel.

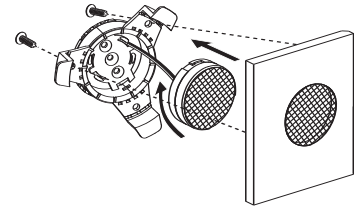

**Figure 6D.** In-dash location (may require gluing).

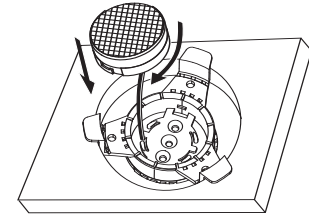

## SPECIFICATIONS

---

### 1011t

Type: 1" Tweeter  
Speaker Impedance: 4 Ohms  
Power Handling: 50W RMS, 150W Peak  
(with supplied crossover)  
Sensitivity (2.83V, 1m): 91dB  
Frequency Response: 2.5kHz – 51kHz  
Mounting Depth: 5/8" (16mm)  
Cut-out Diameter: 1-3/4" (45mm)

### GENERAL CARE

The loudspeaker grilles may be cleaned with a damp cloth. Do not use any cleaners or solvents on the grilles or the speaker cones.

**A valid serial number is required for warranty coverage.**

Features, specifications and appearance are subject to change without notice.



Infinity Systems • 250 Crossways Park Drive, Woodbury, NY 11797 USA  
516.674.4463 • FAX 516.682.3523 • [www.infinitysystems.com](http://www.infinitysystems.com)  
© 2005 Harman International Industries, Incorporated • Part No. REF1011TOM1/05  
H A Harman International Company

### Declaration of Conformity



We, Harman Consumer Group International  
2, route de Tours  
72500 Chateau-du-Loir  
France

declare in own responsibility that the product  
described in this owner's manual is in compliance  
with technical standards:

EN 61000-6-3:2001  
EN 61000-6-1:2001

A handwritten signature in black ink, appearing to read 'Klaus Leberherz'.

Klaus Leberherz  
Harman Consumer Group International  
Chateau-du-Loir, France 1/05